

EU650

EU650 HWT

*Lubricated vane
vacuum pump*

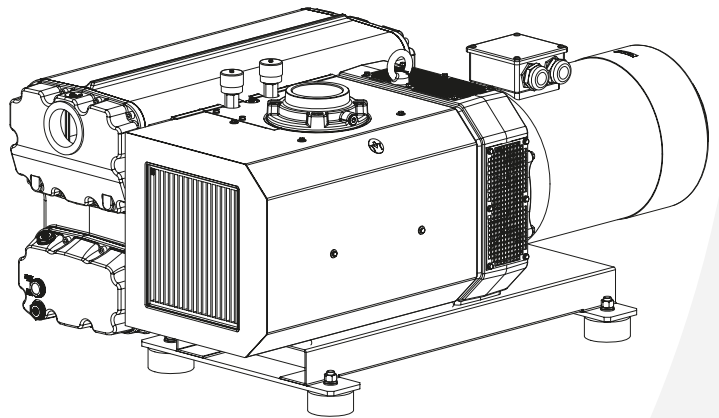

Technical data and parts lists

Publication Number:
RDT 3946.02 April 2021

Technical data and parts lists

EN

Index

Overall dimensions and main parts	pag.4
Technical characteristics	pag.5
General exploded view	pag.6
Circuits exploded view	pag.7
Body of pump exploded view	pag.8
Tank exploded view	pag.9
Spare parts list	pag.10
Accessories exploded view	pag.12
Spare parts list for accessories	pag.13

Overall dimensions and main parts

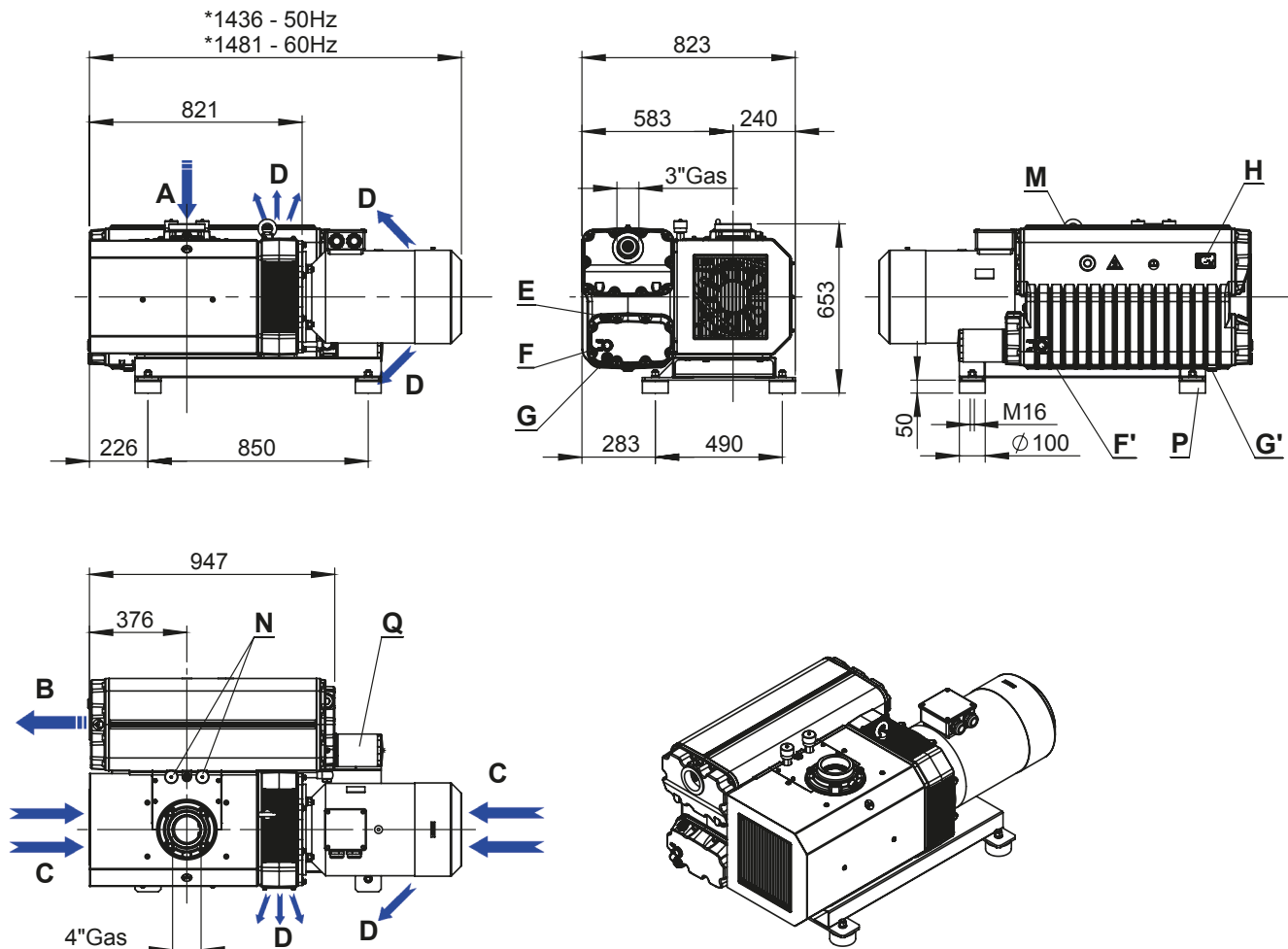

- A Inlet
- B Exhaust
- C Cooling air inlet
- D Cooling air outlet
- E Oil filling plug
- F-F' Oil level sight glass
- G-G' Oil drain plug
- H Pump name plate
- M Lifting eyebolt
- N Gas ballast valve
- P Vibration damper
- Q Oil filter

*Dimensions subject to changes depending on the motor brand

Technical characteristics

		EU650	EU650 HWT
Portata nominale* Nominal speed* Débit nominal* Nennsaugvermögen* Caudal nominal*	m ³ /h	660	
		790	
Pressione limite totale con zavorratore chiuso* (OFF) Ultimate total pressure with gas ballast valve closed* (OFF) Vide final total avec lest d'air fermé * (OFF) Grenzdruck bei geschlossenem Gasballastventil * (OFF) Presión final total con valvula gas-ballast cerrada * (OFF)	mbar	-	
	Pascal	-	
Pressione limite totale con zavorratore aperto* (ON) Ultimate total pressure with gas ballast valve open* (ON) Vide final total avec lest d'air ouvert *(ON) Grenzdruck bei offenem Gasballastventil * (ON) Presión final total con valvula gas-ballast abierta * (ON)	mbar	≤ 0,5	≤ 0,8
	Pascal	≤ 50	≤ 80
Potenza motore # / Numero di giri Motor power # / Rotational speed Puissance moteur # / Numéro de révolutions Motorleistung # / Drehzahl Potencia motor # / Velocidad de giro	50Hz ~3	15 kW - 1000 min ⁻¹	
	60Hz ~3	18,5 kW - 1200 min ⁻¹	
² Caratteristiche motore elettrico ² Electric motor characteristics ² Caractéristiques moteur électrique ² Motoreigenschaften ² Características motor eléctrico	50Hz ~3	IM B5 - Δ400/Y690 V	
	60Hz ~3	IM B5 - Δ460 V UL CSA - IM B5 - YY230/Y460 V IM B5 - Δ220/Y380 V	
Livello di pressione acustica (senza zavorratore) Sound pressure level (without gas ballast valve) Niveau de pression acoustique (sans lest d'air) Schalldruckpegel (ohne Gasballastventil) Nivel de presión acústica (sin valvula gas-ballast)	dB(A) EN ISO 2151	50Hz	73
		60Hz	76
Pressione max vapore H ₂ O ammissibile Water vapour tolerance Pression de vapeur d'eau maximale admissible Wasserdampfverträglichkeit Presión máxima de vapor de agua admisible	mbar	50Hz	30
		60Hz	40
Quantità vapore H ₂ O ammissibile Water vapour pumping capacity Capacité de pompage de la vapeur d'eau Wasserdampfkapazität Cantidad de vapor de agua admisible	kg/h	50Hz	15
		60Hz	22,5
Carica olio Oil capacity Charge d'huile Ölfüllmenge Carga de aceite	l	22	
Peso totale / senza motore Total weight / Without motor Poids total / Sans moteur Gesamtgewicht / Gewicht ohne Motor Peso total / Sin motor	kg	50Hz	582 / 392
		60Hz	612 / 392
<p>*Secondo accordi PNEUROP 6602. *According to Pneuop standard 6602. *Selon la norme Pneuop 6602 *Nach der Pneuop Norm 6602. *Según la normativa Pneuop 6602.</p> <p>#Valido per temperature fino a 40°C e altitudini inferiori a 1000 m. #Valid for temperatures up to 40°C and altitudes lower than 1000 m. #Valable pour températures jusqu'à 40°C et pour altitudes inférieures à 1000 m. #Gültig für Temperaturen bis 40°C und für Höhen weniger als 1000 m. #Válido para temperaturas hasta 40°C y altitudes inferiores a 1000 m.</p>		<p>^{*2} Da definire in funzione del paese d'utilizzo ^{*2} Depending on the Country of use ^{*2} A établir selon le Pays où il sera employé ^{*2} Festzulegen aufgrund von Nutzungsland ^{*2} Definir en función del país de utilización</p>	

General exploded view

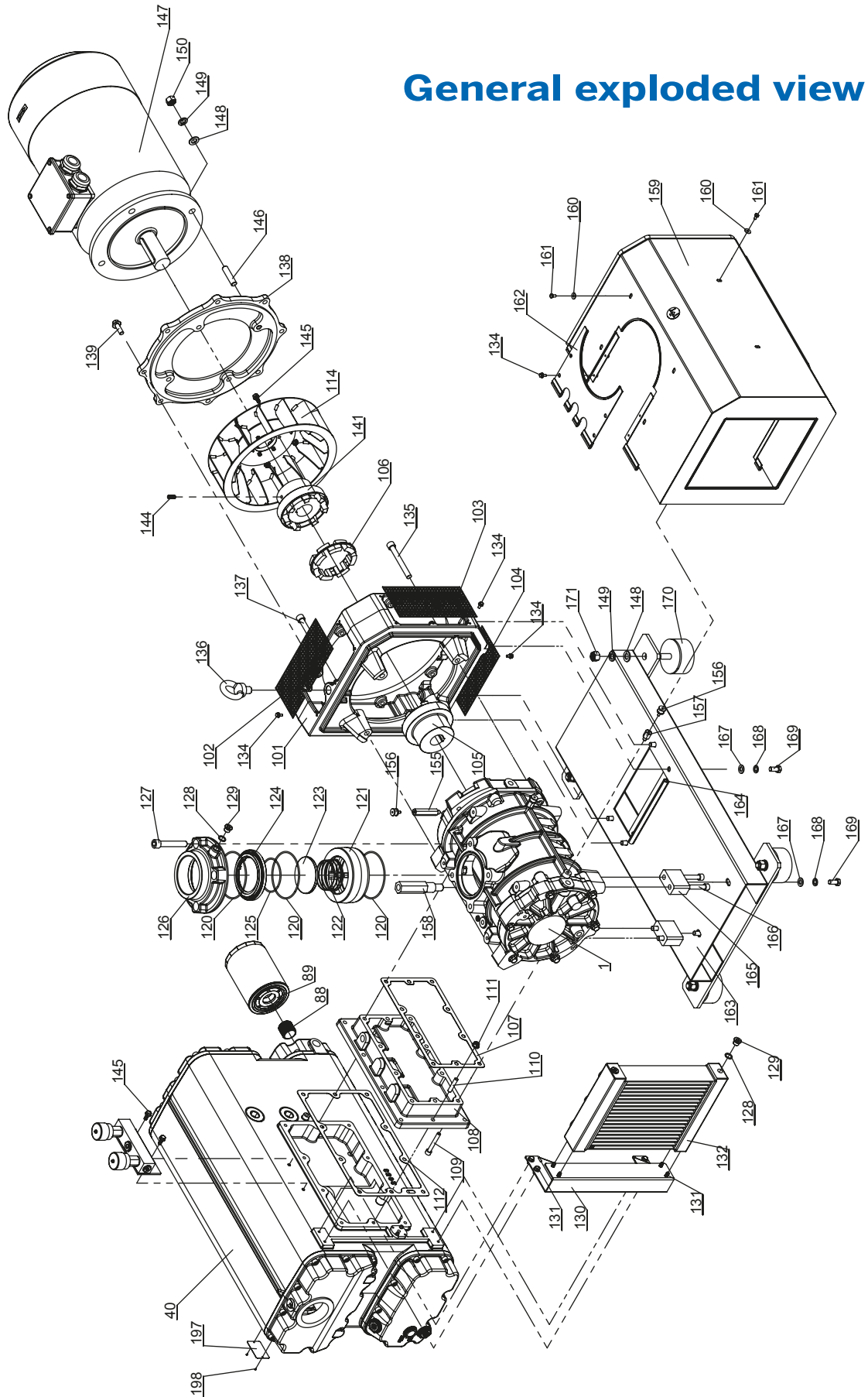

Circuits exploded view

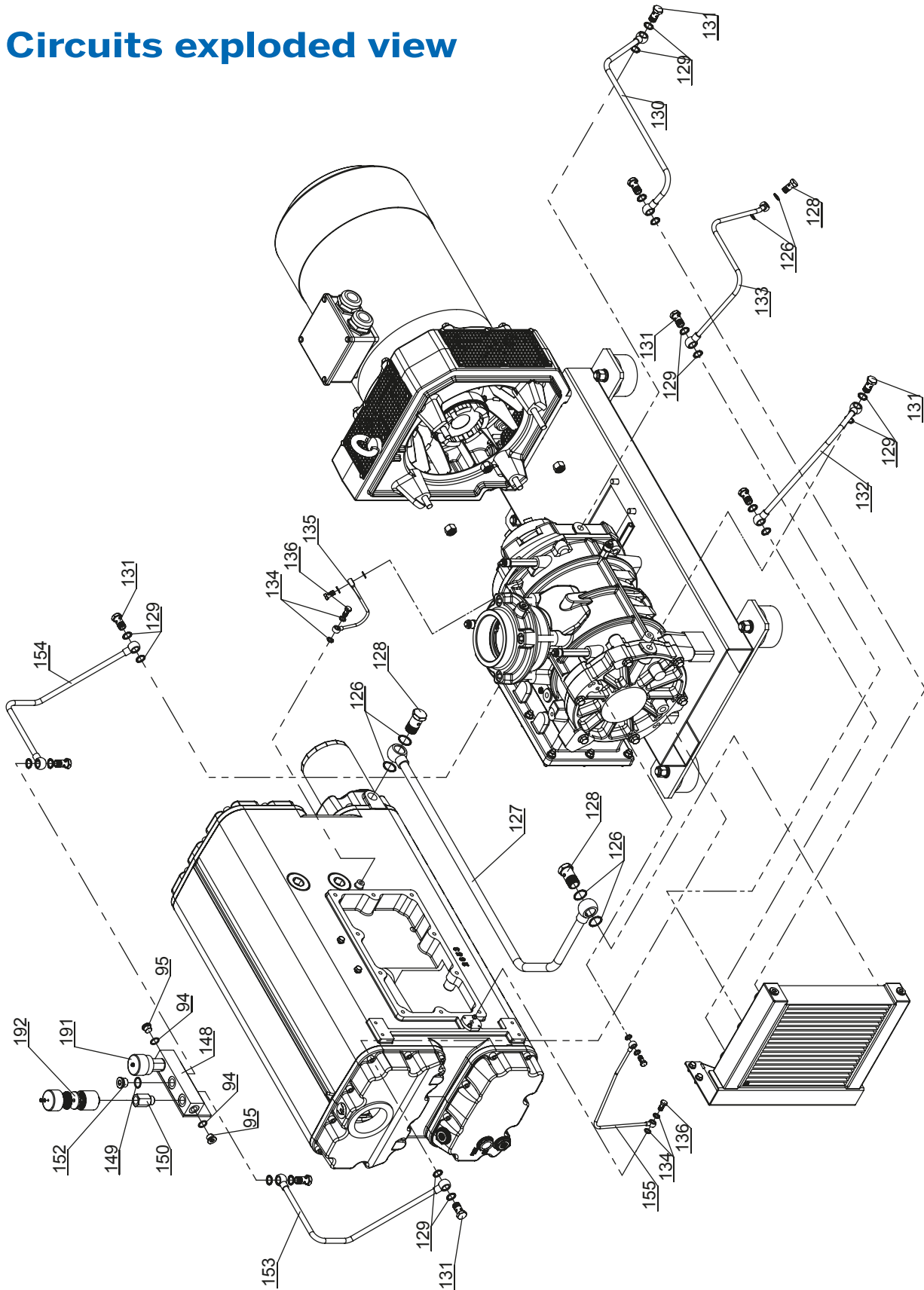

Body of pump exploded view

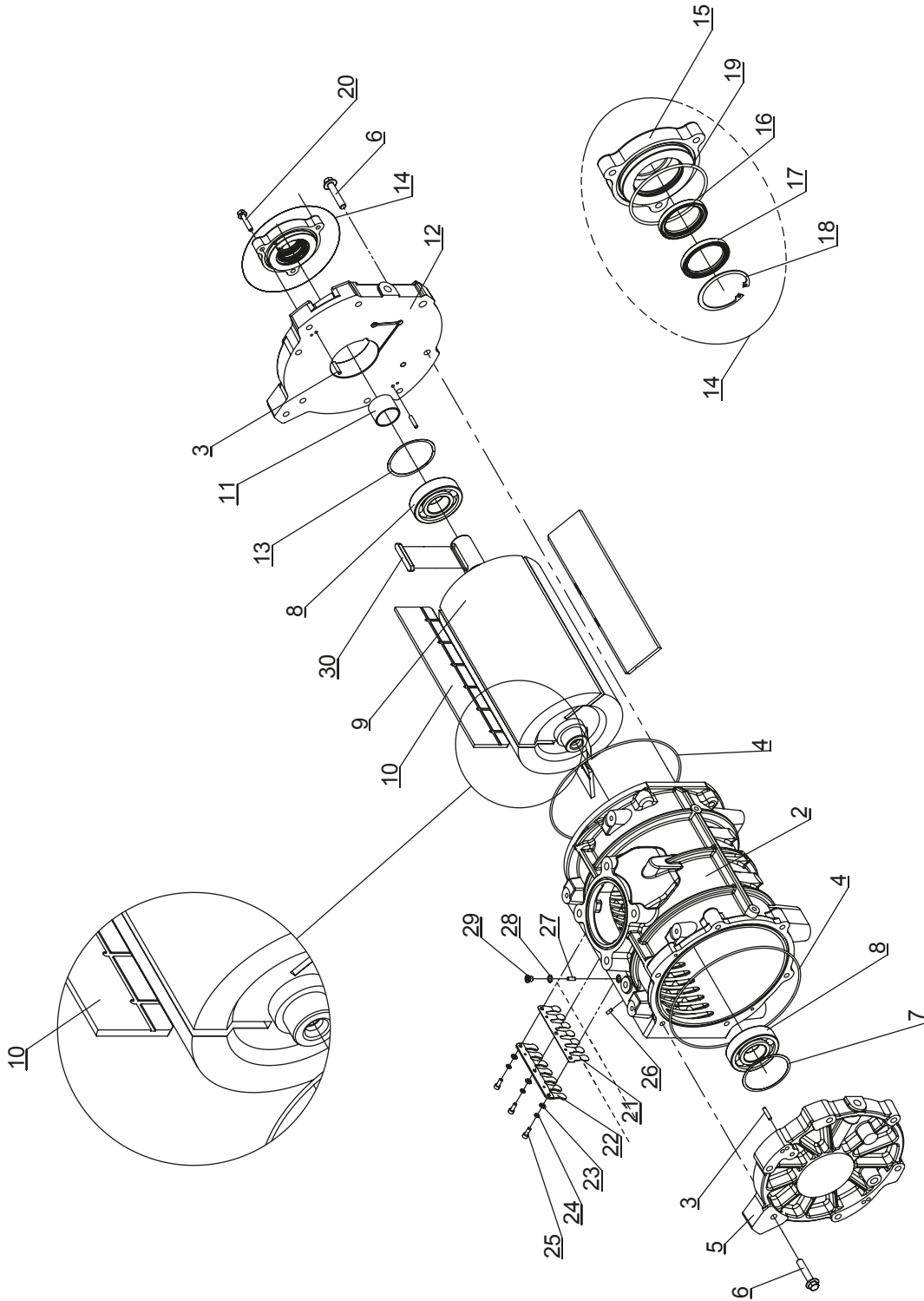

Technical data and parts lists

EN

Spare parts list

POS.	KIT	DESCRIPTION	PZ
1		Pump body assembly	1
2		Body of pump	1
3		Ø6x30 Pin	4
4	G1	O-Ring 41050	2
5		External side cover	1
6		M12x60 Hex. Screw (flanged and knurled)	11
7		D100 Space washer	1
8	S	6309 Ball bearing	2
9		Rotor	1
10		Vane	3
11		IR 45x50x35 Bushing	1
12		Motor side cover	1
13		Shim ring	1
14		Oil seal ring cover assembly	1
15		Oil seal ring cover	1
16	G1	BABSL 50x65x7 Seal ring	1
17	G1	BAB 50x65x7 Seal ring	1
18		Ø68x2,5 Seeger	1
19	G1	O-Ring 4400	1
20		M8x40 Hex. Screw (flanged and knurled)	3
21	S	Plate	4
22		Plate support	4
23		Ø6 washer	12
24		Ø6 Lock washer	12
25		M6 x 16 Hex. Socket head screw	12
26		M5x12 Hex. Socket set screw	4
27		Ø2,5mm reduction (M6x16)	4
28	G2	1/8"G Al Washer	5
29		1/8"G Plug	5
30		A 12x8x70 Key	1
40		Tank assembly	1
41		Tank	1
42	G2	1/4"G Al Washer	1
43		1/4"G Hexagon socket head plug	1
44	G2	3/4"G Al Washer	1
45		3/4"G Hexagon socket head plug	1
46		Motor side upper cover	1
47	G2-R	Upper cover gasket	2
48		M10x30 Hex. Socket head screw	36
49		Demister support mesh	1
50		Tank demister	1
51		Stay bolt for exhaust filter	5
52	G1	O-Ring 4200	10
53	R	Exhaust filter	5
54		Exhaust filter stay bolt sleeve	5
55		Disk for exhaust filter	5
56		Ø8/24 Washer	5

57	G2	Al ø8.4/13x1 Washer	5
58		M8 x 25 Hex. Socket head screw	5
59	G2	1" 1/2 G Al washer	6
60		1"1/2 Gas plug	6
61		External side upper cover	1
62		Tank mesh	1
63		Tank micro-stretched sheet	1
64		Motor side lower cover	1
65	G2	Gasket for lower cover	2
66	R	1" Oil sight glass	2
67	R	1"G Fiber Washer	4
68	G2	1" 1/4 G Al Washer	1
69		1" 1/4 G Plug	1
70		Ext. side lower tank cover	1
71		1"G Filling/discharge plug	2
76		Floating valve	1
77	G1	Rubber seal	1
79	G	OR 108	1
83		Float port	1
84	G1	O-Ring 4093	1
85		M4x8 Hex. Sock. Stud bolt	1
86		Ø5 washer	2
87		M5x16 Hex. Socket head screw	2
88		1"1/4G Nipple	1
89	R	Oil filter	1
100		Fan cover assembly	1
101		Fan cover sleeve	1
102		Sleeve upper safety mesh	1
103		Sleeve side safety mesh	1
104		Sleeve lower safety mesh	1
105		Coupling half pump side	1
106	R	Elastic coupling insert	1
107	G2	Body of pump-spacer gasket	1
108		Pump-tank spacer	1
109		M10x70 Hex. Socket head screw	10
110		M10x35 Stud bolt	10
111		M10 Nut flanged and knurled	10
112	G2	Tank-spacer gasket	1
120	G1	O-Ring 4512	3
121		Inlet valve body	1
122		Helicoidal spring	1
123		Inlet valve plate	1
124		Inlet valve disk assembly	1
125	G1	O-Ring 4362	1
126		Inlet flange	1
127		M16x95 Hex. Socket head screw	4
128	G2	3/8"G Al Washer	5
129		3/8"G Hexagon socket head plug	5

Spare parts list

POS.	KIT	DESCRIZIONE	PZ
130		Oil cooler support	1
131		M8x16 Hex. screw (flanged and knurled)	8
132		Oil cooler	1
134		M6x12 Hex. screw flanged and knurled	22
135		M14x120 Hex. Socket head screw	1
136		M20 Eyebolt	1
137		M14x90 Hex. Socket head screw	3
138		Motor flange	1
139		M12x35 Hex. screw (flanged and knurled)	8
140		Fan Assembly	1
141		Motor side coupling half	1
116		Fan	1
144		M10x25 Hex. Socket set screw	1
145		M8x20 Hex. screw (flanged and knurled)	8
146		M16x67 stud bolt	4
147		Electric motor	1
148		Ø16 Washer	8
149		Ø16 Lock washer	8
150		M16 Nut	4
155		Vibration damping foot extension (long)	4
156		Vibration damping foot	6
157		Vibration damping foot extension (short)	2
158		Eyebolt extension	1
159		Casing assembly	1
160		Ø6 Washer	6
161		M6x12 Hex. head screw fully threaded	6
162		Casing cover	1
163		Base-plate	1
164		Casing sheath	1
165		Pump body support	2
166		M12x60 Hex. Socket head screw	4
167		Ø12 washer	6
168		Ø12 elastic washer	6
169		M12x25 Hex. head screw fully threaded	6
170		Ø100 Vibration damping foot	4
171		M16 Nut	4
175	G2	3/4"G Cu washer	4
176		Oil cooler-tank oil pipe	1
177		3/4"G Hollow bolt	2
178	G2	3/8"G Cu washer	18
179		Motor side lubrication pipe	1
180		3/8"G Hollow bolt	9
181		Ext. side lubrication pipe	1
182	G2	1/4"G Cu washer	2
183		Central lubrication pipe	1
184		1/4"G Hollow bolt	1
185	G2	1/8"G Cu washer	8

186		Oil pipe (outlet seal ring)	1
187		1/8"G Hollow bolt	4
188		Distributor for gas ballast valve	1
189	G2	1/2"G Al Washer	3
190		M/F 1/2" Extension	2 (3 HWT)
191		1/2"G Gas ballast valve	2 (3 HWT)
192	G1-R	Gas ballast felt disk	2 (3 HWT)
193		1/2" G Plug	1
194		Gas ballast pipe (front side)	1
195		Gas ballast pipe (rear side)	1
196		Oil recovery pipe	1
197		Pump name plate	1
198		Ø1.85x5 Tapping rivets	2

MINOR SERVICE KIT	R
VITON SEALS KIT	G1
PRINTED GASKETS KIT	G2
MAJOR SERVICE KIT	S+G1+G2+R

Accessories exploded view

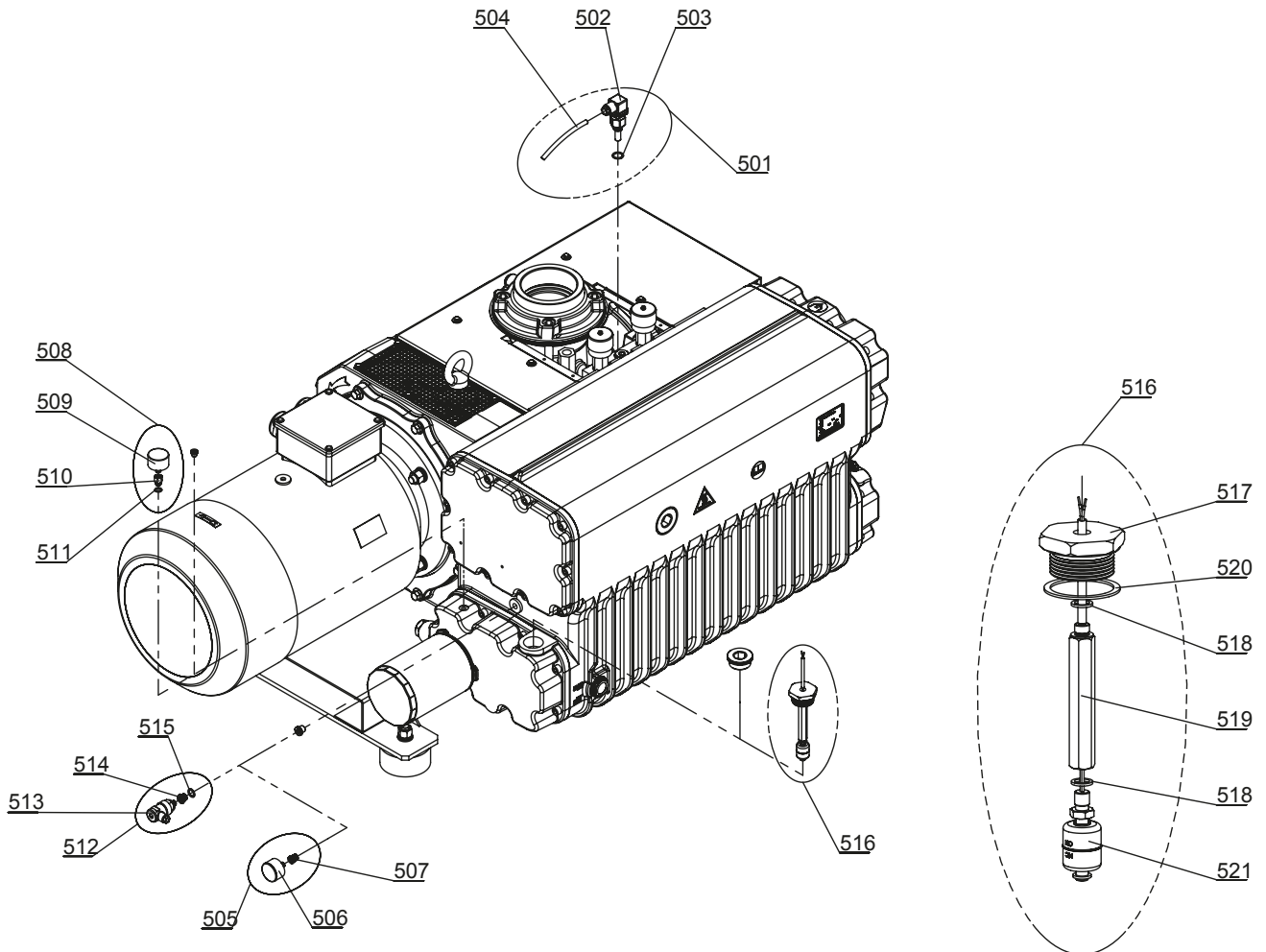

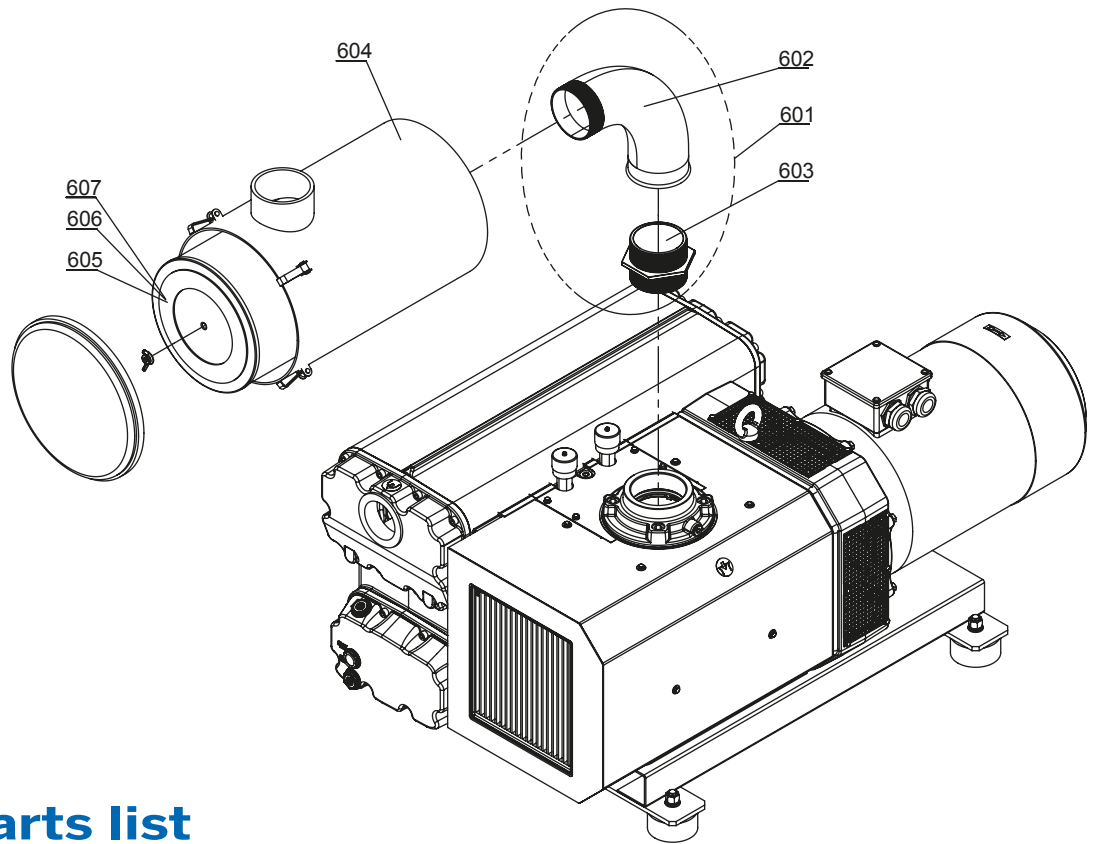

Spare parts list for accessories

POS.	KIT	DESCRIPTION	PZ
501		Pump thermal protection switch	1
502		Safety temperature switch	1
503		3/8"G AI Washer	1
504		Silicone cable	1
505		Pressure gauge kit	1
506		Pressure gauge for exhaust filter	1
507		M-f 1/4"-1/8" G adapter	1
508		Vacuum gauge kit	1
509		Vacuum gauge oil filter clogging	1
510		1/8"-1/8" M/F Extension	1
511		1/8"G AI Washer	1
512		Exhaust filter control pressure switch	1
513		Pressure switch	1
514		1/4"-1/8"G M-f Cyl. Reduction	1
515		1/4"G AI Washer	1
516		Oil level switch assembly	1
517		Oil level switch port	1
518		1/8"G AI Washer	2
519		Oil level switch extension	1
520		1" 1/4 G AI Washer	1
521		Minimum oil level indicator	1

Spare parts list for accessories inlet filter

POS.	KIT	DESCRIPTION	PZ
601		Connection fitting kit for gas filter	1
602		4"G M-F G4 Union fitting	1
603		4"G N8 Nipple	1
604		Inlet filter	1
605	C	Paper filter element	1
606	C	Stainless steel filter element	1
607	C	Polyester filter element	1

CONSUMABLE

C

PVR Srl **SEDE LEGALE E AMMINISTRATIVA:**

Via Santa Vecchia, 107 - 23868 Valmadrera (LC), Italy
T +39 0341 1918 51 - F +39 0341 1918 599
info@pvr.it - www.pvr.it

UNITÀ LOCALE:

Via IV Novembre, 104F
23868 Valmadrera (LC), Italy